

ICELEDTM

ELECTRO STYLING

SCANNER INSTALLATION GUIDE OPERATING GUIDE

WARNING

THIS PRODUCT HAS BEEN DELIBERATELY DESIGNED TO CREATE A HIGHLY NOTICEABLE LIGHTING EFFECT THAT WILL TURN HEADS AT CAR SHOWS AND EXHIBITIONS. BECAUSE OF THIS IT IS EXTREMELY IMPORTANT THAT IT IS **NOT USED ON THE PUBLIC HIGHWAY** TO PREVENT THE DISTRACTION OF OTHER ROAD USERS.

HAVING ISSUED THIS WARNING ICELED WILL NOT ACCEPT ANY RESPONSIBILITY FOR ISSUES ARISING FROM ANY FAILURE TO COMPLY WITH THIS CLEAR INSTRUCTION.

ICELED WILL NOT ACCEPT RESPONSIBILITY FOR ANY OTHER ISSUES ARISING FROM IMPROPER USE OR FITTING OF THIS PRODUCT AS THESE MATTERS ARE BEYOND OUR CONTROL.

THIS PRODUCT IS CAPABLE OF PRODUCING STROBOSCOPIC LIGHTING EFFECTS.

Features

ICELED Scanner is a self-contained moving light effect that reproduces a sweeping scan pattern in **over two million colours**. The scan can be left to run with colours that cycle automatically or can be fixed on a single chosen colour.

An optional connection is provided to allow the scanner to receive data from other ICELED controllers. This provides access to range of different scan patterns and also provides a means for synchronising colour and reaction to a music beat.



Installation

The scanner is weatherproof so is suitable for mounting in exposed locations as well as indoors.

Wiring

The cable attached to the scanner has three wires:

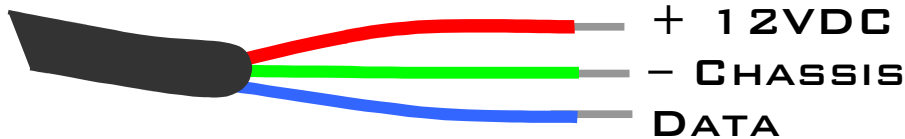

There are a several wiring options that ultimately determine the degree of control available over the scanner:

Wiring for standalone mode

The simplest option is to provide a connection to a 12Volt DC supply (e.g. a car battery) via a fuse and a switch. Note that the blue data wire should be connected to the chassis along with the green 0V wire in this scheme:

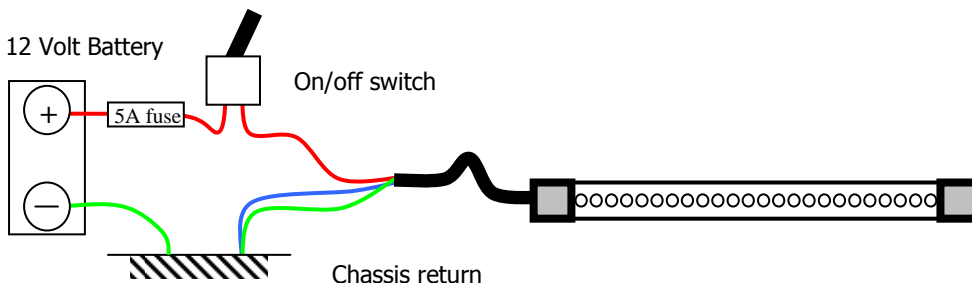

Wiring to a ZAP+ Controller

This miniature ICELED controller can be used to gain extra control over the scan colour and pattern. Using ZAP+ does away with the need for a switch (as required in standalone mode) as the controller provides a means to program colour etc. It also allows the scanner to be switched on and off while being connected to a permanent supply voltage.

The Red, Green and Blue wires from the scanner are simply wired to the corresponding output terminals marked R G B on the junction box – just like any other ICELED light source:

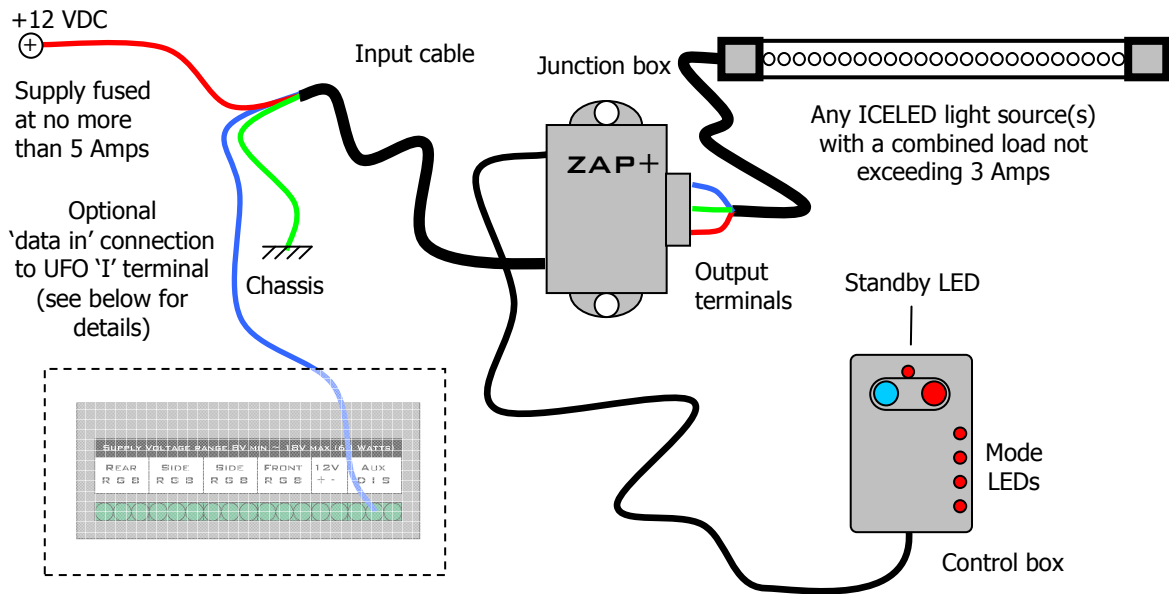

Note that other ICELED light sources e.g. TRON may also be connected in parallel with the scanner to serve as a local indication of colour and effect if the scanner is in a remote location. One scanner uses roughly half the load capacity of the ZAP+ controller so there is plenty of spare capacity for the connection of additional light sources.

Optional 'data in' connection

The blue wire in the ZAP+ input cable may be connected to another controller such as UFO. This optional connection allows ZAP+ to select between it's own colours and patterns and those of the external controller. With this arrangement the scanner can be operated independently or in parallel with UFO and also may be switched on and off (put into low-power standby) from the control box.

If the blue data wire in the input cable is unused it should be connected to chassis along with the green wire.

Wiring to a UFO controller

If a UFO controller is available the scanner may be operated in parallel with the underbody kit using the UFO remote control. The scanner data wire (blue) should be connected to the terminal marked I as shown below. The power (red) and ground (green) wires can be paired with the UFO supply connections or taken to separate power sources if required.

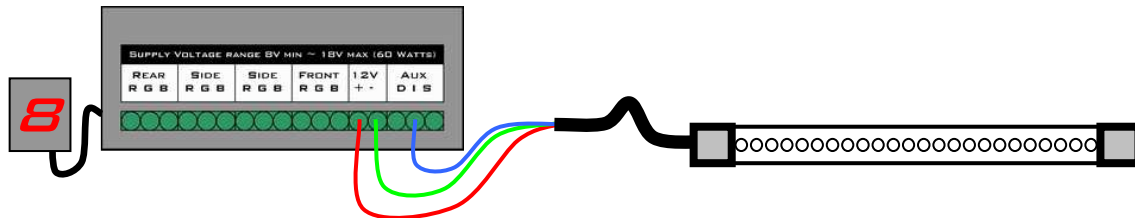

Switching the scanner on and off

The scanner will always switch on and off along with UFO when wired as above. If it is desirable to operate the scanner independently from UFO then a switch may be used to break the +12VDC connection to the scanner. Either way the scanner cable should be protected either by the fuse supplying UFO, or via an additional fuse connecting it to an alternative +12VDC source.

Note that such a switch is unnecessary if a ZAP+ controller is used between UFO and the scanner as shown in the ZAP+ wiring diagram in the previous section. This is because ZAP+ can be used to inhibit the scanner from switching on with UFO.

Operation

The scanner will operate in a number of different ways depending on how it is connected.

Operation in standalone mode

In standalone mode the scan pattern will resemble a moving Comet with a fading tail. The length of the tail will vary randomly over time. Initially the scanner will power-up showing white for around 20 seconds then gradually change colour through the rainbow in a cyclic fashion:

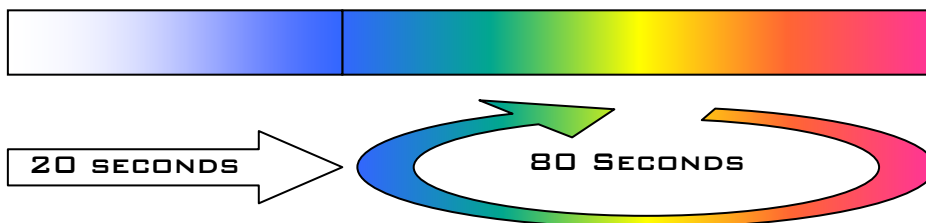

Freezing on a colour

The scanner may be frozen on any colour (including the initial white) by briefly interrupting the power supply. To do this, quickly flick the supply switch off then on again within less than half a second. This will freeze the scanner on the current colour. A red flash will confirm that colour changing has been halted. From this point on the scan will only be displayed in this one colour. The scanner also remembers that it is frozen on this particular colour for all subsequent power-ups.

Unfreezing the colour

To return from a frozen colour to cyclic colours briefly interrupt the power supply once more. A green flash will confirm that the scanner is free to change on its own from now on. This is also remembered for subsequent power-ups.

Operation with a ZAP+ controller

When connected to the output of a ZAP+ controller, it becomes possible to select the scan colour and also select one of four different built-in scan patterns. It also allows the scanner to be put into a low-power standby mode (effectively switching it off) and provides synchronisation between music picked-up by the internal microphone and the behaviour of the scan in the beat and strobe modes. The following table summarises the effects available:

ZAP+ Mode	Scan colour	Scan pattern
• <i>Standby/bypass</i>	<i>Off/external</i>	<i>Off/external</i>
• STATIC	Fixed choice	Comet tail
• PHASE	Auto colour sweep	Random Waves
• BEAT	Random on beat	Twin pulse on beat
• STROBE	White on beat	Random segments

Refer to the ZAP+ manual for a description of each mode and the parameters that may be adjusted.

External control - Inhibiting the scanner

In standby/bypass mode, if a UFO controller is connected to the ZAP+ data input (see ZAP+ wiring in the previous section) UFO will take control of the scanner. However, if the ZAP+ blue button is pressed once more the scanner will be locked into standby regardless of any commands received. This allows the scanner to remain off while UFO is switched on and off for example. The scanner will remain in this inhibited state until the next time the red button is pressed

The standby LED on ZAP+ provides an indication of its current state – if the scanner is responding to external data the LED will light brightly. If it is inhibited (or if no external control is present) it will only be dimly lit. This provides a useful indication of whether or not the scanner is operating.

Operation with a UFO controller

When connected to the "Interior" data output (I terminal) of a UFO controller (either directly or indirectly through a ZAP+ in bypass mode), scan colours and patterns will follow pattern changes along with UFO. The 11 built-in scan patterns have been designed to complement the corresponding UFO patterns:

- Patterns 2 through L can be made sound reactive by using the audio button on the UFO handset. For each of these patterns the scan colour is determined by the colour range of the UFO pattern selected – so changing to match the underbody display. A unique scan pattern is also created to complement each UFO pattern.
- For pattern 1 (Static), the scanner will slowly cycle a full-width bar through all the colours of the rainbow irrespective of the UFO palette.
- For pattern 0 (Streetwise), the scanner will display a full-width bar in either white or red with an optional 'chaser' that randomly scans over the top. The 'chaser' can be switched on or off using the audio button on the UFO handset. When the red dot on the remote display is lit, the 'chaser' is active.

Changing the streetwise colour

To change the streetwise colour from white to red requires the use of the UFO handset: With UFO switched on and with pattern 0 (streetwise) selected press the audio button in order to turn on the red dot on the remote display (if it is already on press the audio button to switch it off, then press again to switch it back on).

Then, within two seconds turn off UFO (and the scanner) using the power key. This will program the scanner to show red from now on. To change back to white follow the same procedure as above but aim to turn the red dot off before pressing the power key.

Specifications

Nominal supply voltage:	12 Volts DC ⁽¹⁾
Standby current drain:	0.01 Amps
Maximum load current:	1.7 Amps
Data input:	Any ICELED controller output
Dimensions:	Length 20"(508 mm) ⁽²⁾ Nominal diameter 1" (25 mm)

⁽¹⁾ Voltage range of between 6 and 28 Volts. Reverse polarity and over-voltage protection are built in.

⁽²⁾ Including end-caps

Resources

To see the full ICELED product range visit <http://www.iceled.co.uk> the official ICELED website.

For more suggestions and advice visit <http://iceled.co.uk/area51/> the official ICELED user forums.

ICELED SCANNER Conforms to:
EMC Directive (2004/108/EEC)
